

未注公差/General tolerances(mm)											0.1/10 ±2'		
0	>3	>6	>10	>18	>30	>50	>80	>120	>180	>250		>315	>400
±0.12	±0.18	±0.22	±0.26	±0.31	±0.37	±0.57	±0.80	±0.93	±1.05	±1.15	±1.60	±2.20	±2.50

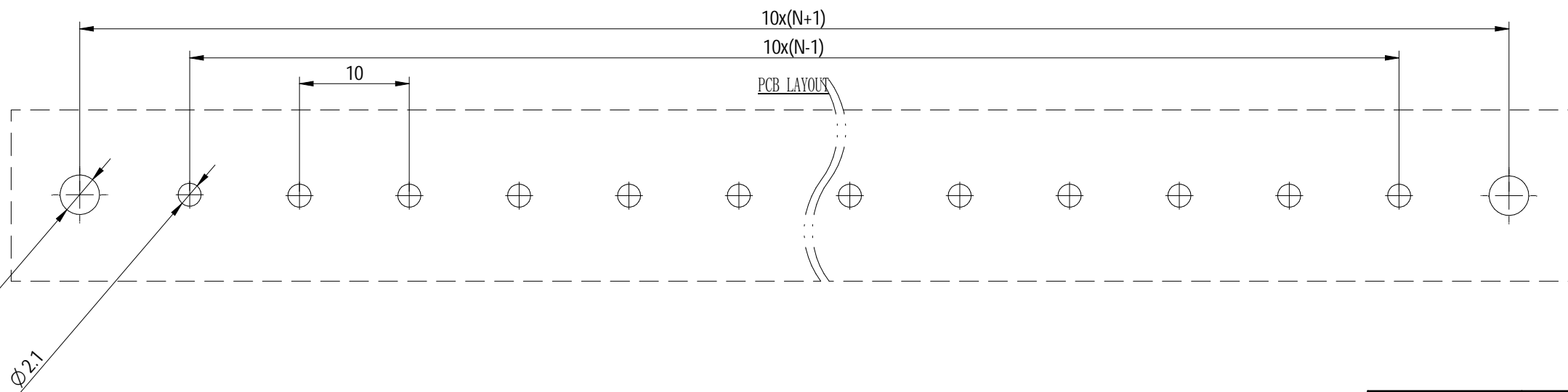
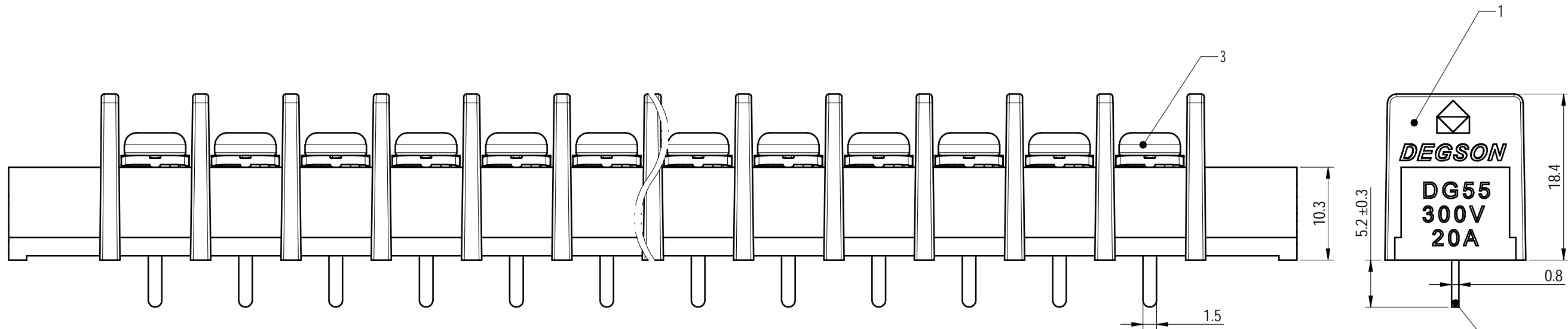
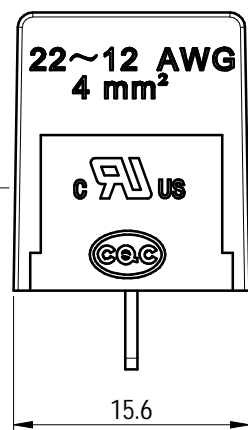
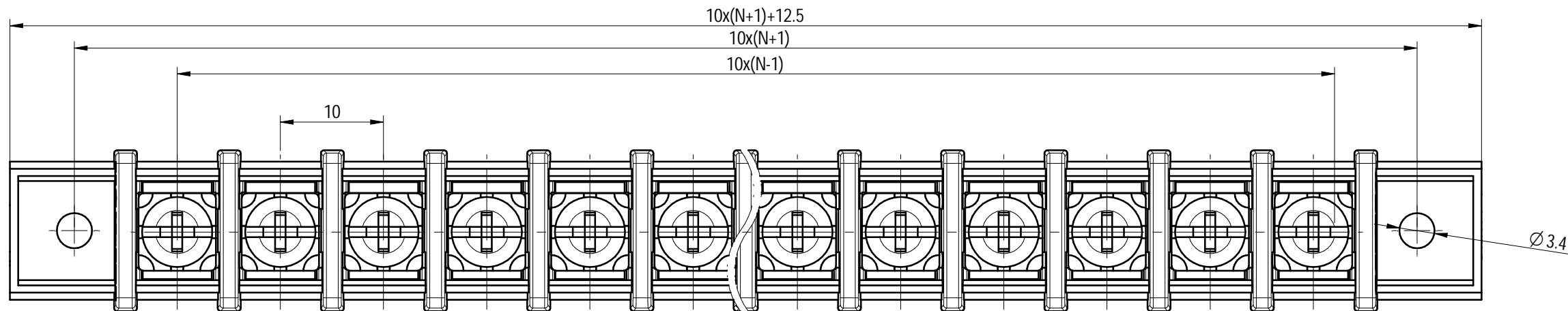

Note: The A&Z (H) in the name means :A(H) and Z(H)

ITEM	NAME OF PART	MATERIAL	NOTES
3	Screw	Steel	M4/Ni plated
2	Pin header	Brass	Sn plated
1	Housing	PA66	UL94V-0
UL 标准/UL Standard:			
额定电压/电压/Rated Voltage(V)/Current(A)	B	C	D
300/20	300/20	300/10	300/10
螺丝扭矩/Torque Tightening(N·m/Lb.in)	M4, 1.2/10.53		
线径范围(硬线和软线)/Wire Range(rigid and flexible)(AWG/mm²)	22~12 / 0.32~3.3		
间距/Pitch(mm)/线数范围/Poles	10.0/N=02~24P		
使用温度范围/Operating temperature(°C)	-40~+105		
符合RoHS环保要求/Conform to RoHS	Yes		

DEGSON		MATERIAL: /	SURFACE/COLOR: /		
APPD: 核准人	核准日期	MAT NO./REV: /	MAT STATUS: /		
CHKD: 审核人	审核日期	NAME			
DRFT: 设计人	设计日期	DG55C-A-XXP-1Y-00A&Z(H)			
REV	ECN	DESCRIPTION	DRFT	DATE	
00	/	/	/	/	
DRAWING NO. 200321494		TYPE CUSTOMER DRAWING	DRAWING STATUS /	SCALE 2:1	SHEET 1/1

Transfer or duplication of this document as well as the utilization or communication of its contents are prohibited unless explicit authorization is granted. Violations will be liable for compensation. All rights reserved for patent. 复制或再行使用本文件以及其内容之利用或沟通均须经本公司明确授权，否则将承担侵权赔偿责任。本公司保留所有权利。未经许可，不得复制或再行使用本文件。