

PCB LAYOUT

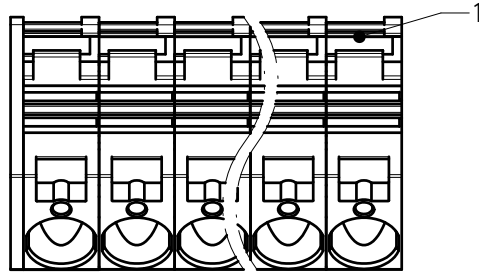

未注公差/General tolerances (mm)													0.1/10 ±2'
0	>3	>6	>10	>18	>30	>50	>80	>120	>180	>250	>315	>400	
~3	~6	~10	~18	~30	~50	~80	~120	~180	~250	~315	~400	~500	
±0.12	±0.18	±0.22	±0.26	±0.31	±0.37	±0.57	±0.80	±0.93	±1.05	±1.15	±1.60	±2.20	±2.50

UL 标准/UL Standard:	B	C	D
额定电压/电流/Rated Voltage(V)/Current(A)	300/66	300/66	/
IEC 标准/IEC Standard:			
过压类别/Overvoltage Category/污染等级/Pollution Degree	III/3	III/2	II/2
额定电压/电流/Rated Voltage(V)/Current(A)	320/76	400/76	630/76
额定脉冲电压 (KV) /Rate Impulse Voltage (KV)	4	4	4
线径范围(硬线和软线)/Wire Range (rigid and flexible)(AWG/mm ²)	24~4 / 0.2~16		
间距/Pitch(mm)/线数范围/Poles	10.0/N=01~16P		
剥线长度/Stripping length(mm)	12~13		
使用温度范围/Operating temperature(°C)	-40~+105		
符合RoHS环保要求/Conform to RoHS	Yes		

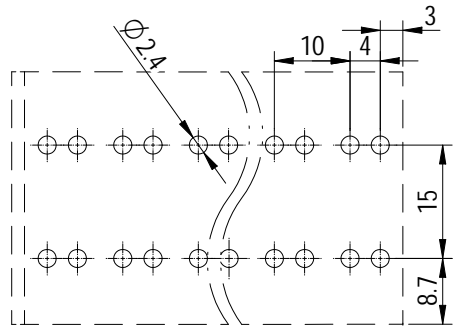
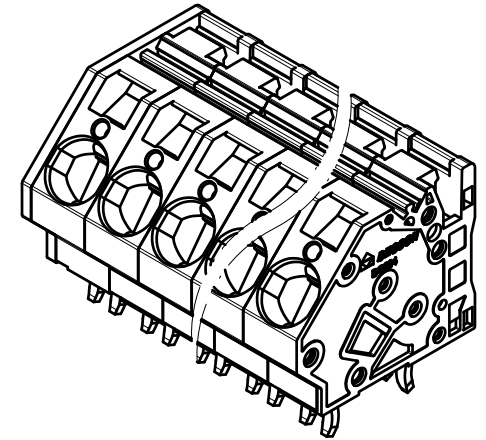
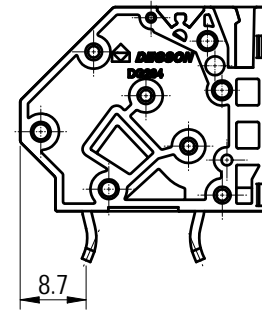
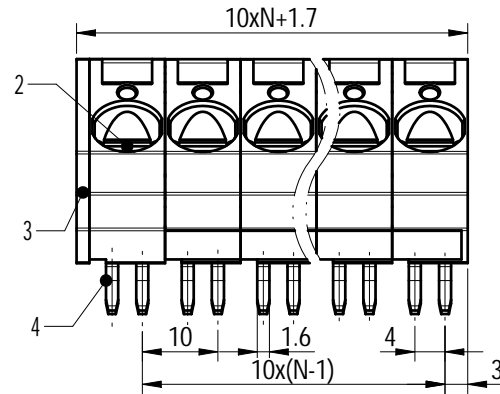
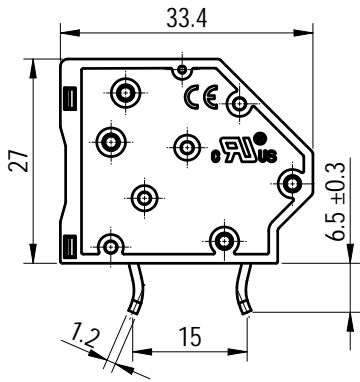

Note:
The A&Z (H) in the name means: A(H) and Z(H).

ITEM	NAME OF PART	MATERIAL	NOTES
4	Pin header	Copper Alloy	Sn plated
3	Cover	PA66	UL94V-0
2	Spring	Stainless steel	/
1	Housing	PA66	UL94V-0

		MATERIAL: /	SURFACE/COLOR: /		
APPD: 兰春华 2023.02.17		MAT NO./REV: - / 00	MAT STATUS: 批量		
CHKD: 陈招 2023.02.17		NAME			
DRFT: 柳学龙 2023.02.17		DG264-10.0-XXP-1Y-00A&Z(H)			
DRAWING NO.	TYPE	DRAWING STATUS	SCALE	SHEET	
200025666	CUSTOMER DRAWING	已发布	1:1	1/1	

REV	ECN	DESCRIPTION	DRFT	DATE
00			柳学龙	2023.02.17

Transfer or duplication of this document as well as the utilization or communication of its contents are prohibited unless authorized in advance. Violations will be punished. We have reserved all rights reserved for patent, utility model or designer registrations. 除专利权明确标注外, 复制、印刷、光碟等文件的传播, 未经事先获得许可, 均属于违法行为。本公司保留对涉及发明、实用新型和外观设计的所有权利。