

PCB LAYOUT

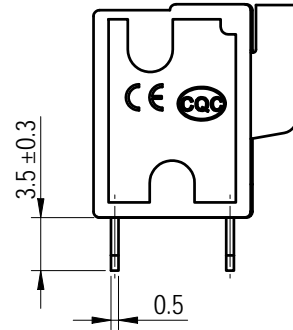

未注公差/General tolerances (mm)													0.1/10
0	>3	>6	>10	>18	>30	>50	>80	>120	>180	>250	>315	>400	
~3	~6	~10	~18	~30	~50	~80	~120	~180	~250	~315	~400	~500	±2'
±0.12	±0.18	±0.22	±0.26	±0.31	±0.37	±0.57	±0.80	±0.93	±1.05	±1.15	±1.60	±2.20	

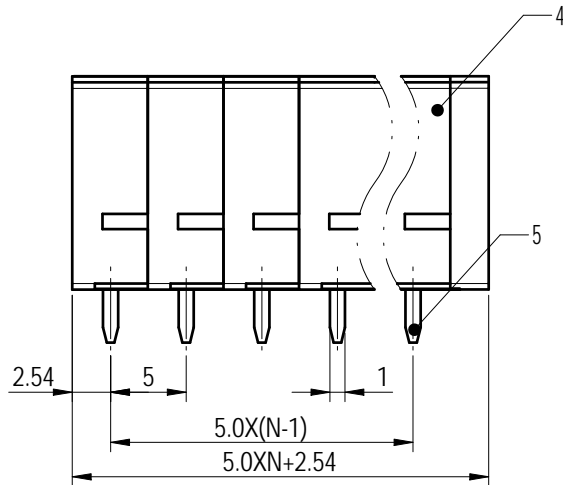
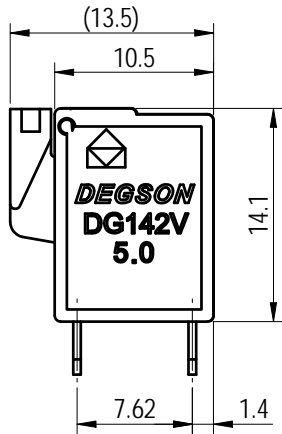
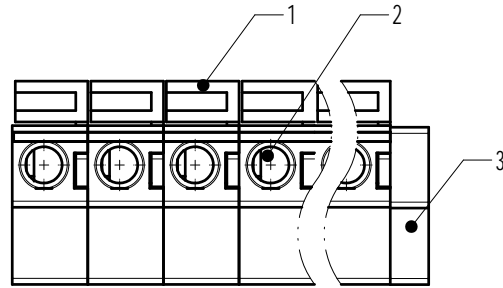
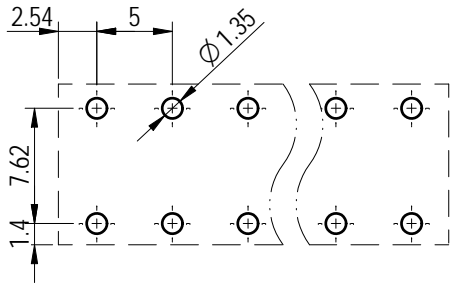
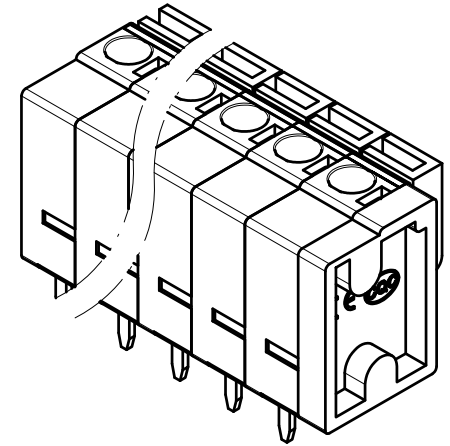

Note:
The A&Z (H) in the name means: A (H) and Z (H).

ITEM	NAME OF PART	MATERIAL	NOTES
5	Pin header	Copper alloy	Sn plated
4	Housing	PA66	UL94V-0
3	Cover	PA66	UL94V-0
2	Spring	Stainless steel	/
1	Button	PA66	UL94V-0

UL 标准/UL Standard:	B	C	D
额定电压/电流/Rated Voltage(V)/Current(A)	300/10	/	/
IEC 标准/IEC Standard:			
过压类别/Overvoltage Category/污染等级/Pollution Degree	III/3	III/2	II/2
额定电压/电流/Rated Voltage(V)/Current(A)	250/15	320/15	630/15
额定脉冲电压(KV)/Rate Impulse Voltage(KV)	4	4	4
线径范围(硬线和软线)/Wire Range(rigid and flexible)(AWG/mm²)	22~16 / 0.2~1.5		
间距/Pitch(mm)/线数范围/Poles	5.0/N=01~24P		
剥线长度/Stripping length(mm)	10		
使用温度范围/Operating temperature(°C)	-40~-105		
符合RoHS环保要求/Conform to RoHS	Yes		

DEGSON

APPD: 兰春华 2022.09.29
CHKD: 陈招 2022.09.29
DRFT: 龚徐涛 2022.09.28

MATERIAL:	SURFACE/COLOR:	
MAT NO./REV:	/ 00	MAT STATUS: 批量
NAME	DG142V-5.0-XXP-1Y-00A&Z(H)	
DRAWING NO.	TYPE	DRAWING STATUS
200029098	CUSTOMER DRAWING	已发布
SCALE	SHEET	
2:1	1/1	

REV	ECN	DESCRIPTION	DRFT	DATE
00			龚徐涛	2022.09.28

Transfer or duplication of this document as well as the utilization or communication of its contents are prohibited unless authorized in writing by DEGSON. All rights reserved for patent. 除专利注明情况外，否则禁止译法、复制、仿用。未经授权，不得复制或传播。 除专利注明情况外，否则禁止复制或传播。 除专利注明情况外，否则禁止复制或传播。