

未注公差/General tolerances (mm)													0.1/10
0	>3	>6	>10	>18	>30	>50	>80	>120	>180	>250	>315	>400	±2'
~3	~6	~10	~18	~30	~50	~80	~120	~180	~250	~315	~400	~500	
±0.12	±0.18	±0.22	±0.26	±0.31	±0.37	±0.57	±0.80	±0.93	±1.05	±1.15	±1.60	±2.20	±2.50

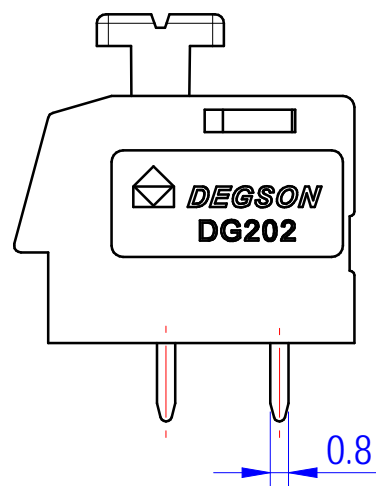

PCB LAYOUT

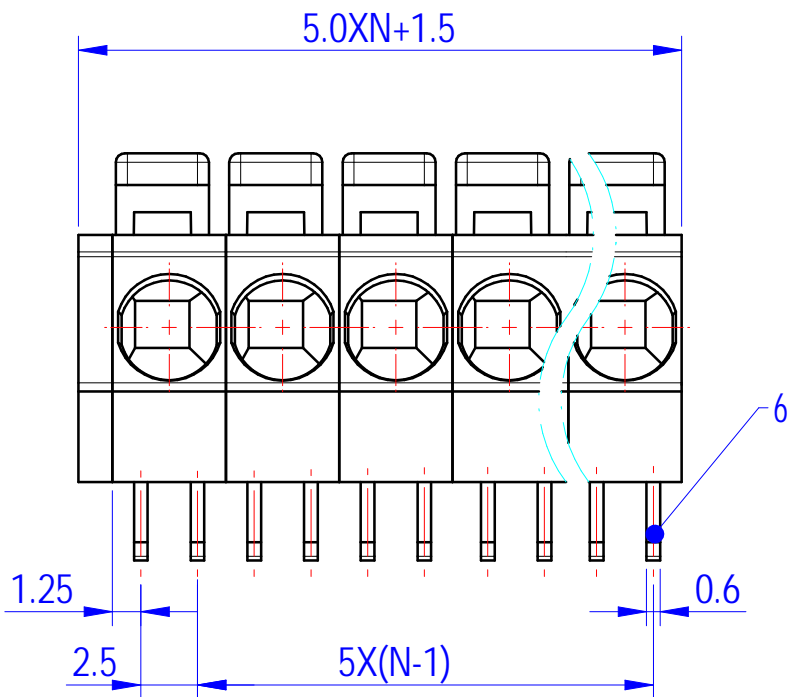
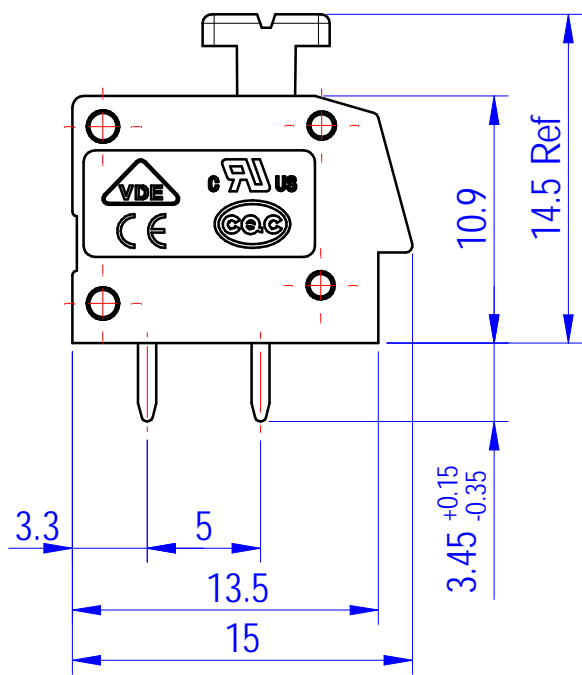
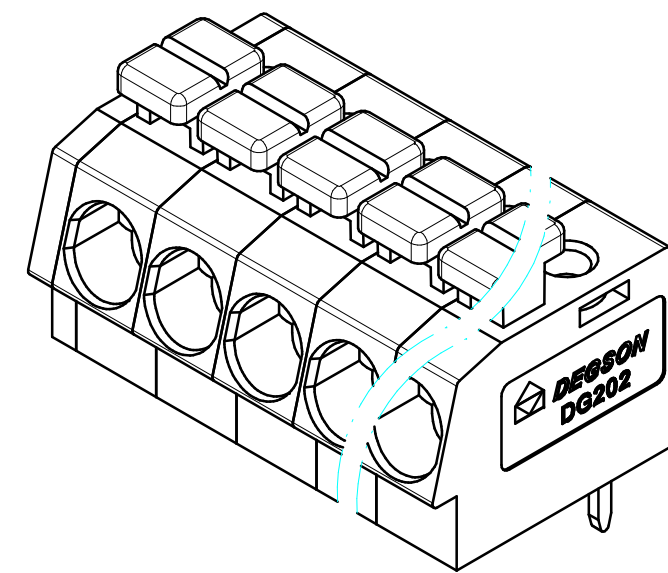
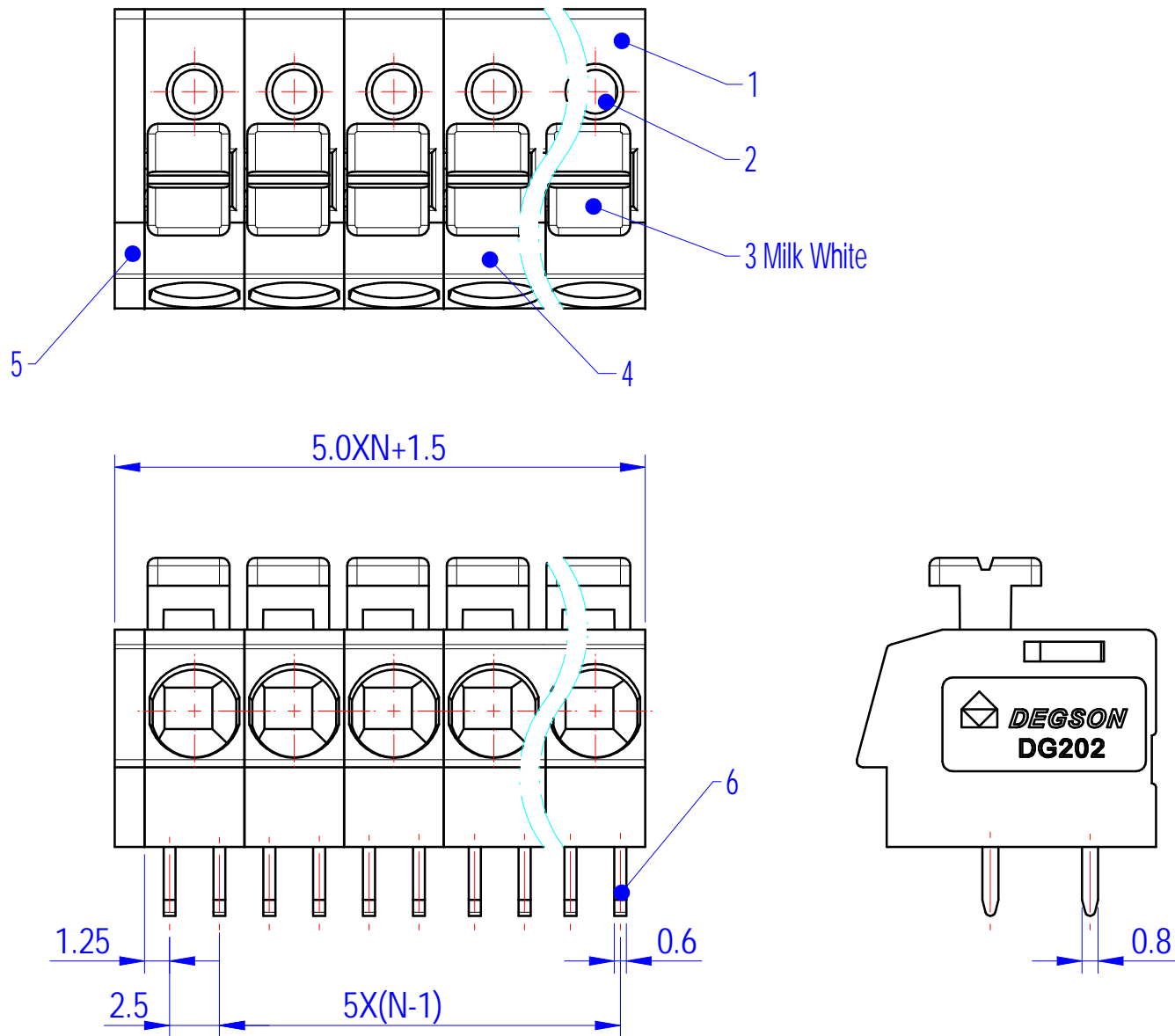
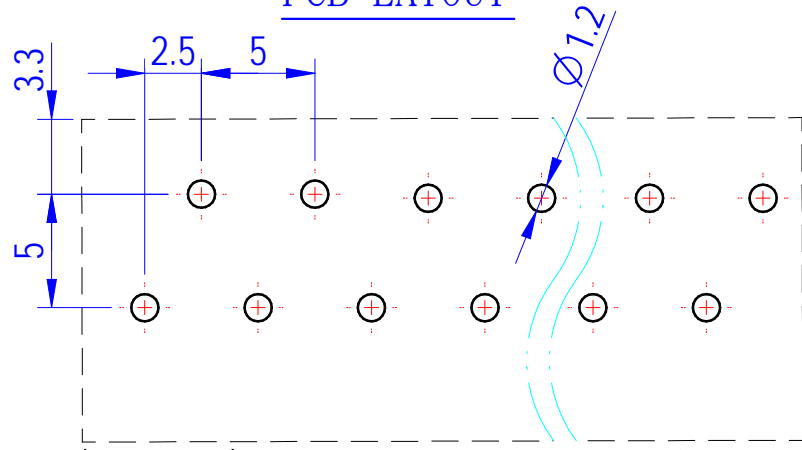

ITEM	NAME OF PART	MATERIAL	NOTES
6	Pin header	Copper	Sn plated
5	Cover	PA66	UL94V-0
4	Center housing	PA66	UL94V-0
3	Button	PA66	UL94V-0
2	Spring	Stainless steel	/
1	Left housing	PA66	UL94V-0

UL 标准/UL Standard:			
额定电压/电流/Rated Voltage(V)/Current(A)	B	C	D
	300/12	/	300/10
IEC 标准/IEC Standard:			
过压类别/Overtoltage Category/污染等级/Pollution Degree	III/3	III/2	II/2
额定电压/电流/Rated Voltage(V)/Current(A)	/	450/16	/
工频耐压/Withstanding Voltage (V/min)	/	AC2500	/
线径范围(硬线和软线)/Wire Range(rigid and flexible)(AWG/mm <sup>2</sup> )	20- 12/ 0.2- 2.5		
间距/Pitch(mm)/线数范围/Poles	5.0/N= 01~ 24P		
剥线长度/Stripping length(mm)	10- 11		
使用温度范围/Operating temperature(°C)	-40~ + 105		
符合RoHS环保要求/Conform to RoHS	Yes		

MATERIAL:		SURFACE/COLOR:	
MAT NO./REV: / 00		MAT STATUS: 批量	
APPD: 兰春华	2024. 10. 08	NAME	
CHKD: 陈招	2024. 10. 08	DG202-5. 0-XXP-1Y-00A&Z(H)	
DRFT: 龚徐涛	2024. 09. 29	DRAWING NO. 200031795	TYPE CUSTOMER DRAWING
REV	ECN	DRAWING STATUS 已发布	SCALE 1:1
02			SHEET 1/1

02		线径范围更正	龚徐涛	2024. 09. 29
REV	ECN	DESCRIPTION	DRFT	DATE

Transfer or duplication of this document as well as the utilization or communication of its contents are prohibited unless explicit authorization is granted. Violations will be liable for compensation. All rights reserved for patent, utility or design registrations. 除经本公司书面许可外, 任何复制或传播行为均属侵权。本公司保留所有权利。未经许可, 不得复制或传播。 未经授权, 不得复制或传播。 未经授权, 不得复制或传播。